



Energy research Centre of the Netherlands

Integrating μ CHP into a distributed energy system with the PowerMatcher

Maarten Hommelberg

ECN - Intelligent Energy Grids



Evolution in the Electricity Infrastructure

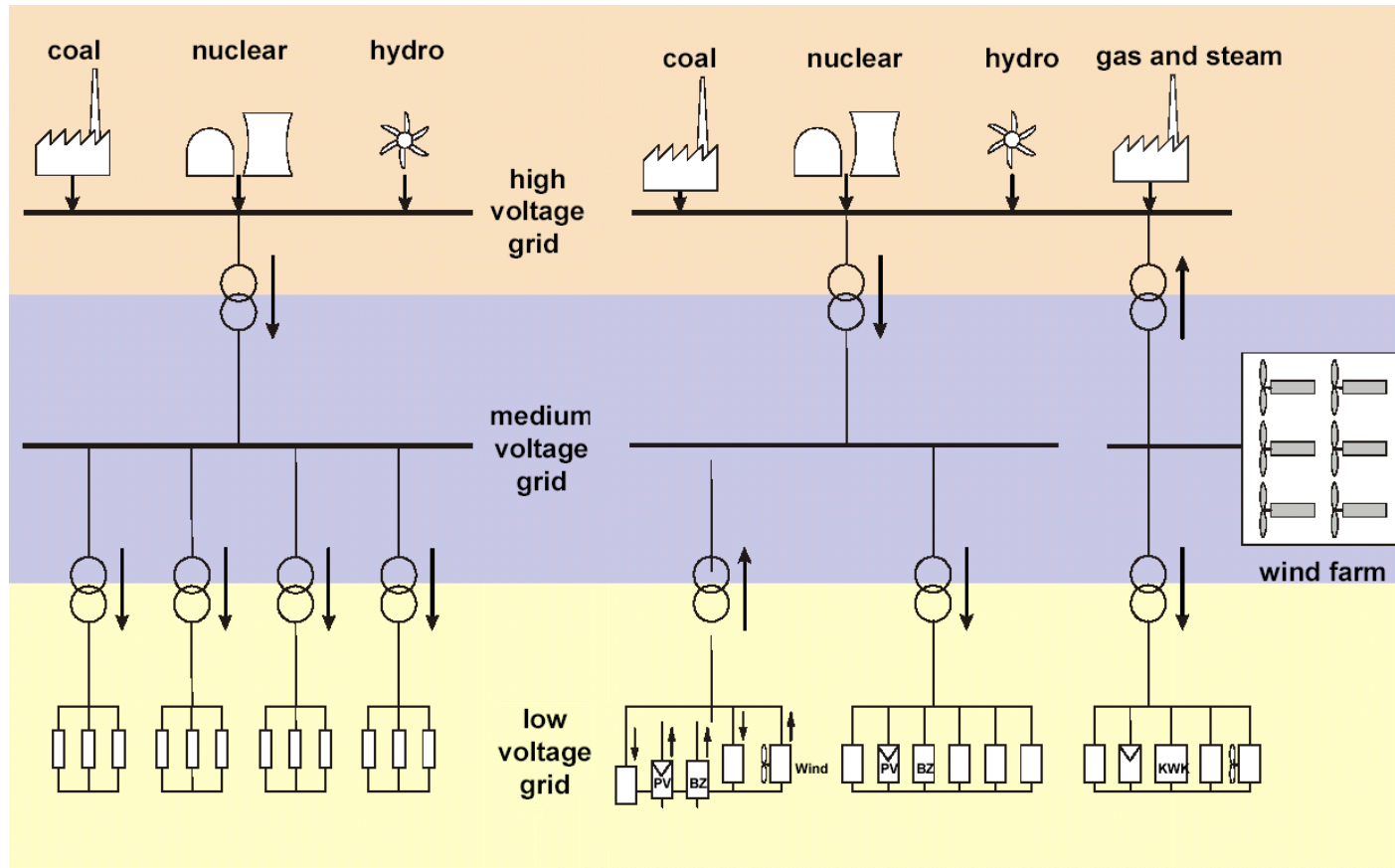

(Drawing courtesy of ISET)

The Challenge of the Changing System

Traditional situation:

- Demand
 - Behaves stochastically
 - Partially predictable
- Supply
 - Large scale production
 - Fully controllable
- Control
 - Centralised
 - Done by the supply-side

Future situation:

- Demand
 - Behaves stochastically
 - Partially predictable
- Supply
 - Behaves stochastically
 - Partially predictable
- **Control Challenges**
 - How to maintain the supply & demand balance?
 - Who delivers system support services?

ECN's contribution to a new control approach for a new system

PowerMatcher

Automatic matching of demand and supply in a system

Based on novel ICT-technologies

Developed in the CRISP project: Further developed in other projects

Can be used for different applications

- **Creation of Virtual Power Plant (topic of this presentation)**
- Reduction of imbalance
- Optimal Dispatch of demand and supply of energy trader
- Reduction of peak load in the system
- Reduction of stress on local MV/LV transformer stations

PowerMatcher overview

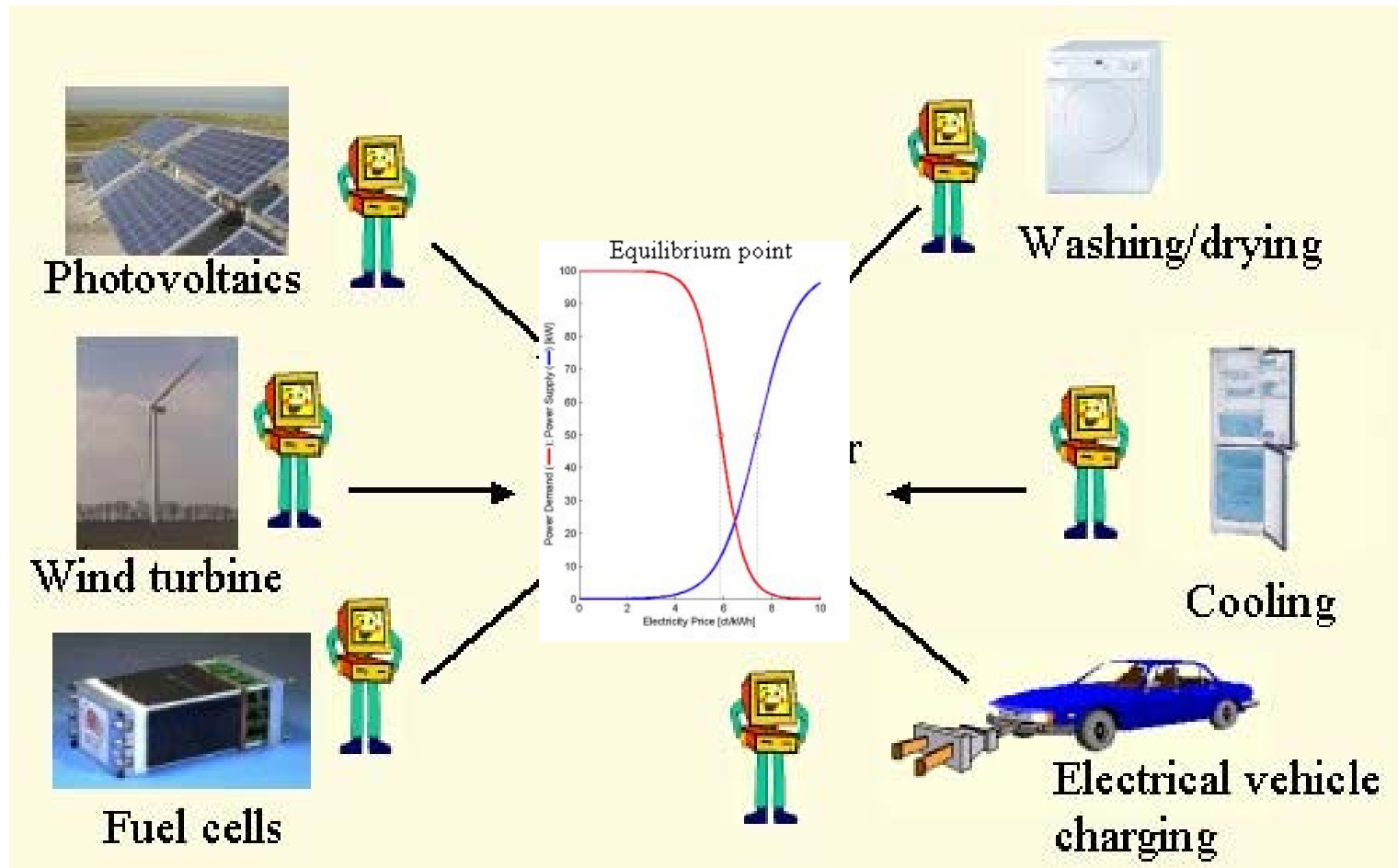

microeconomics, control theory & agents

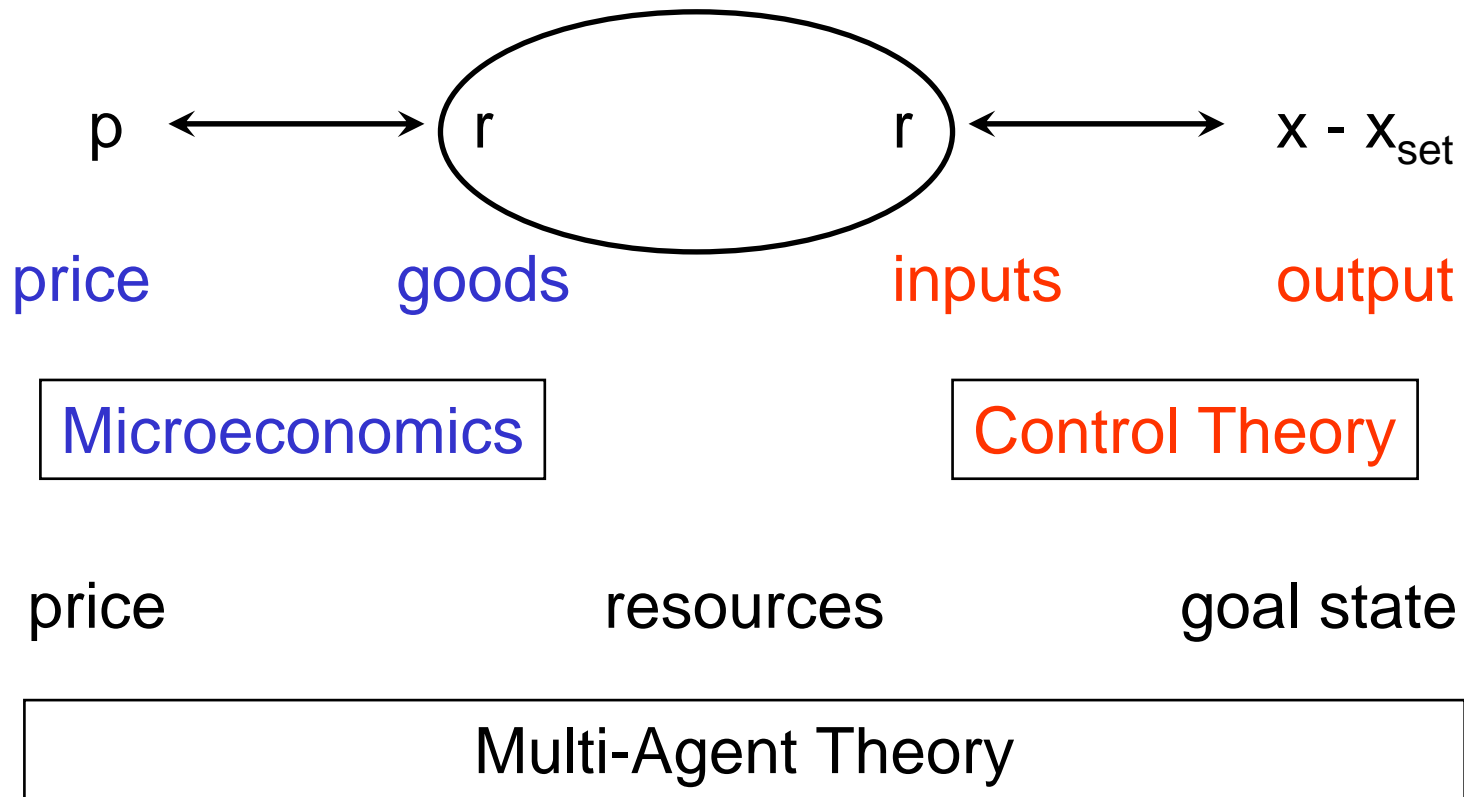

μCHP Virtual Power Plant

Clustered operation of micro-CHPs for grid-support and trading

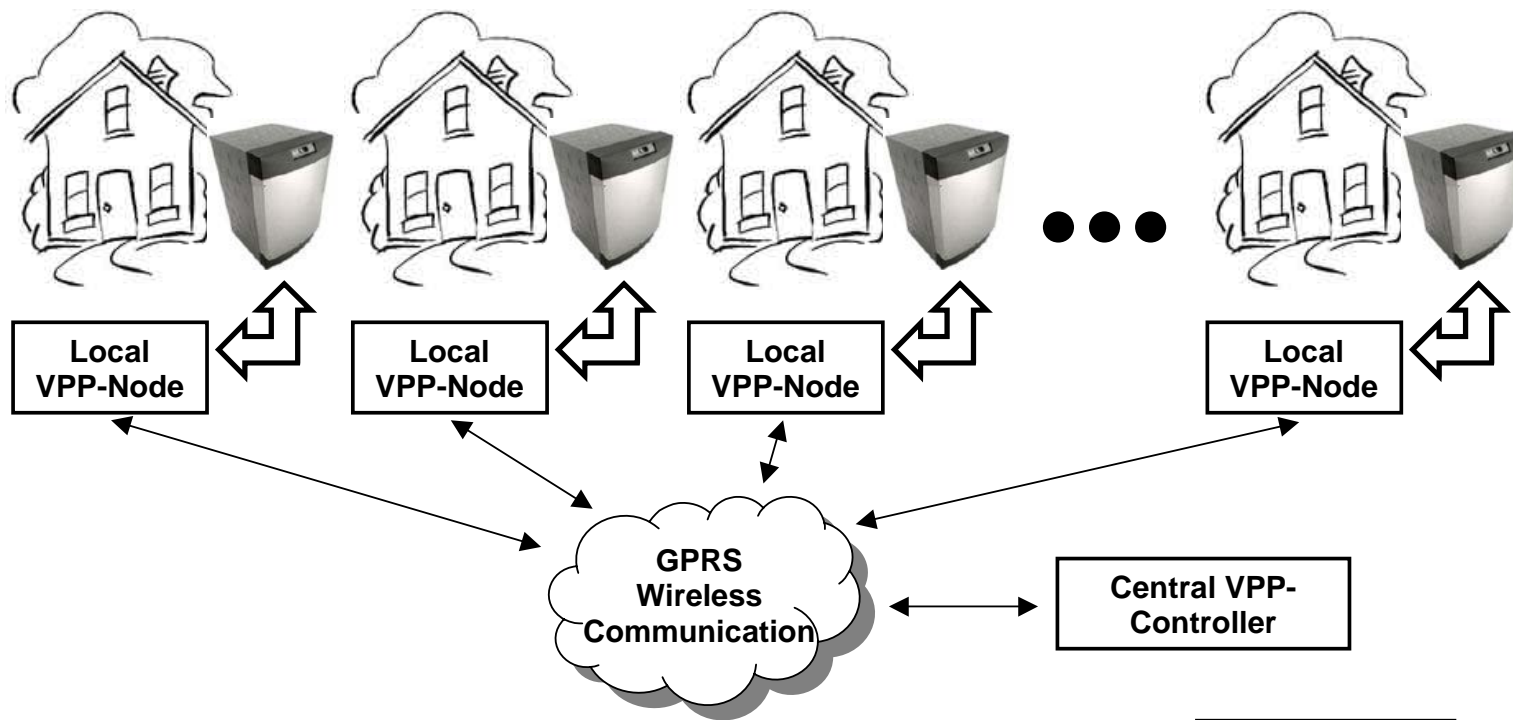

CRISP Fieldexperiment: Commercial Portfolio Management

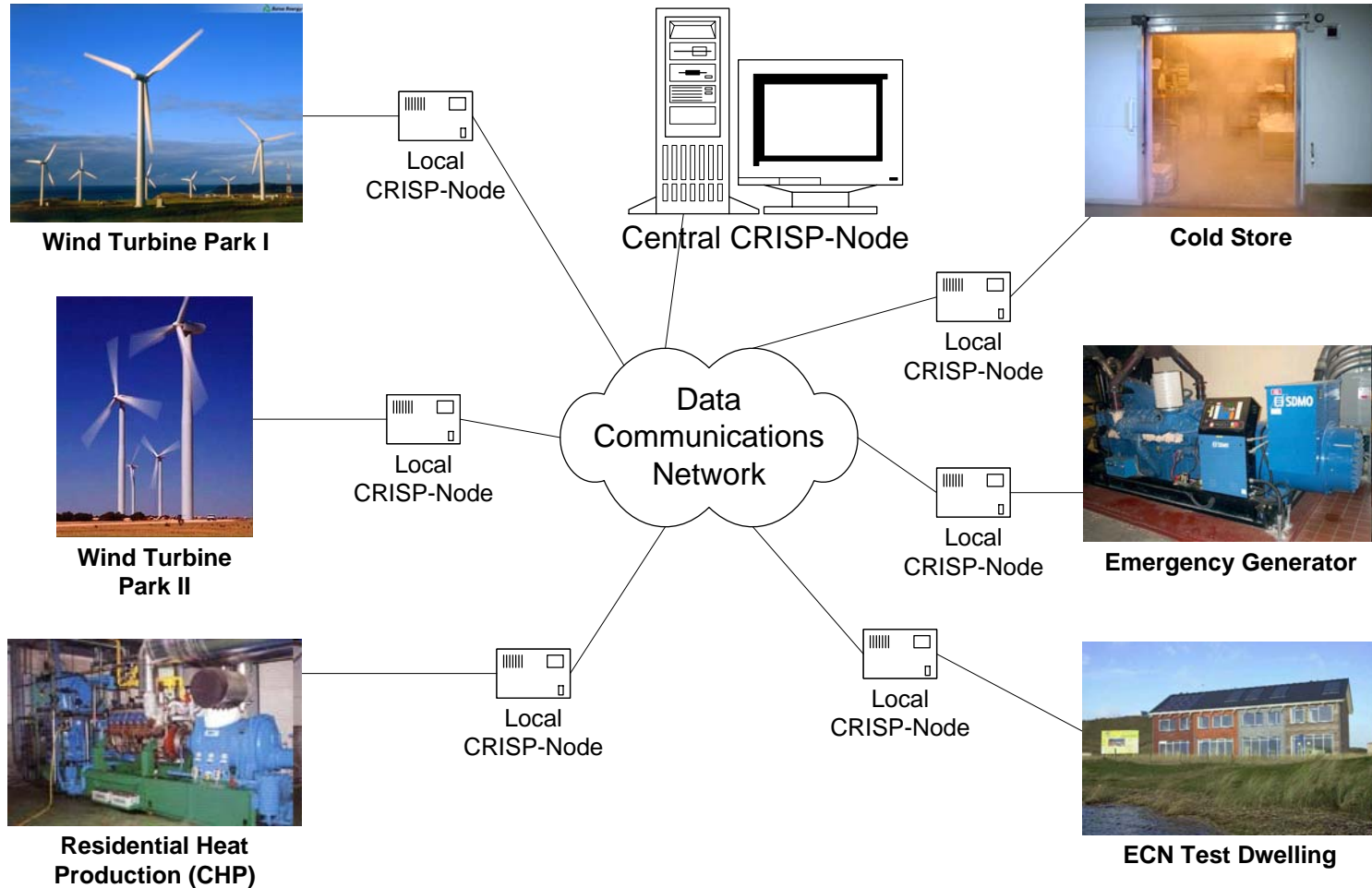

Test dwelling outcome

